



Black

INVICTA *Custom*

X60 Invicta Custom | *by Cal Automotive Creations*



Red Baron

In 1918, on one of his many missions, a Red Baron was shot down and killed. His name was Manfred von Richthofen, a hero of World War I.

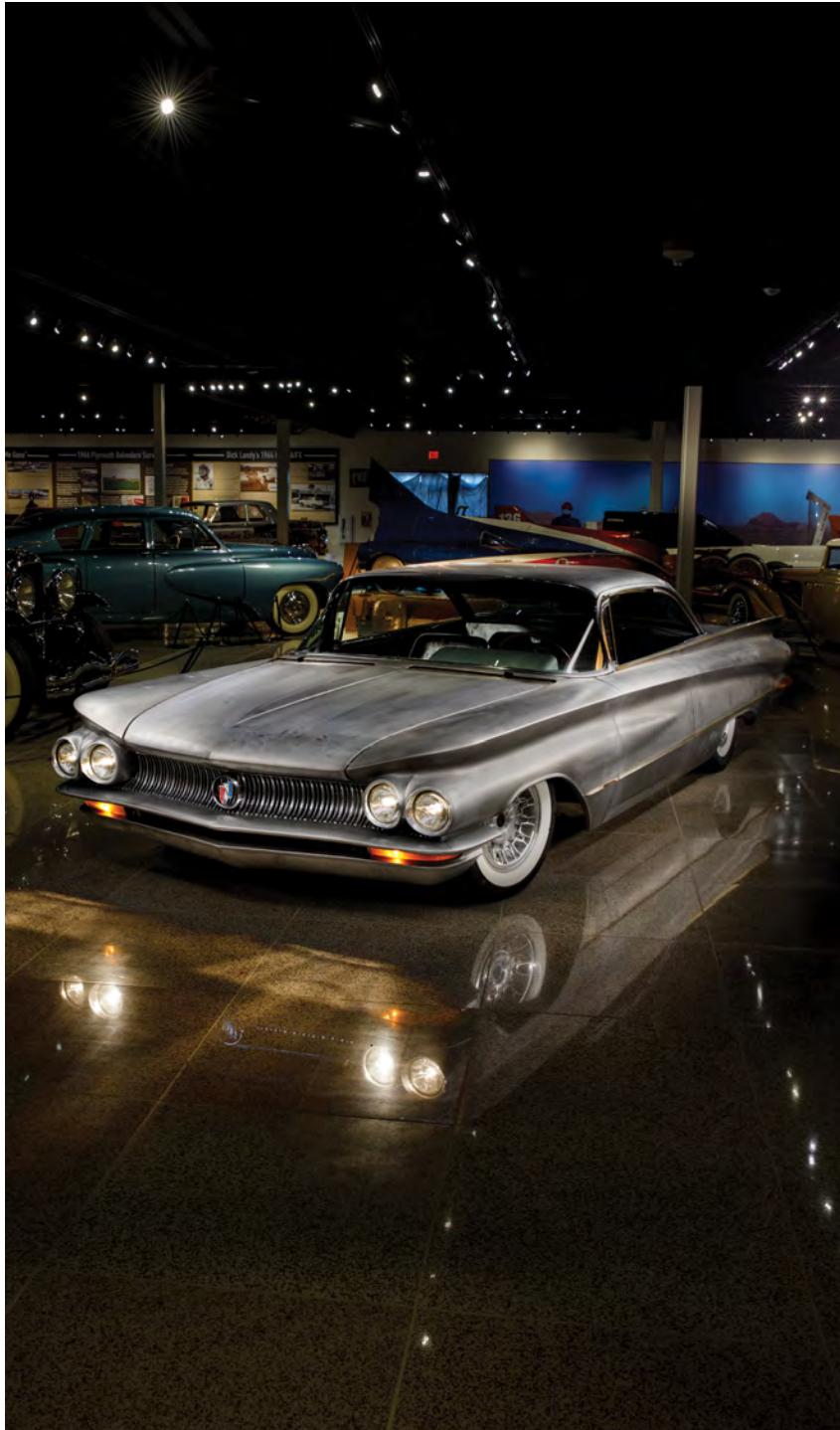

X60 BUICK INVICTA

By 1960, America was dominating the aerospace world with an imaginative and whimsical spirit that delivered sleek, artful, and purposeful designs. Inspired by the time, the 1960 Buick Invicta was modern and forward thinking. To no surprise, its look paid homage to the design wonders of the Boeing B-52 Stratofortress.

In the spirit of what this car stood for in 1960 – and the emotions it evokes today – the X60 Invicta Custom is a restored and custom-built iteration that maintains its original intentions, including details originally lost to budget constraints. This time, it embodies every inch of its potential.

*Owners: George & Angela Eliacostas
Builder: Cal Automotive Creations
Design Consultant: e.Black / eBDCo*



BODY

6

- Jet Age B-52 inspired styling
- Wedge sectioned two inches in the front
- Stock height roof
- Front wheel opening moved forward 1 ½"
- All panels precisely hand-crafted
- CAD designed and precision machined trim
- Manipulated proportions to improve body line flow from front to rear
- Split rear bumper converted to one-piece precision machined bumper
- Hand-crafted front bumper
- Machined brass door handles
- Motor and firewall set back 6"
- Hood lengthened
- Cowl significantly reduced in size for a more sleek and refined look
- Relocated wiper towers to accommodate shortened cowl
- Hand-crafted headlight housings contoured to fenders
- One-off machined tail light bezels with integrated gas fill
- Machined hood hinges and deck lid hinges
- Floor contoured around custom chassis

INTERIOR

14

- Rare Invicta Custom hardback bucket seats with custom pearlized leather
- NOS seat material
- Hand-crafted rear GM hardback bucket seats
- Machined seat trim with custom Invicta logos and courtesy lights
- Custom machined center console with hidden cup holders and charging port
- Hand-formed door panels with custom machined trim and arm rest
- NOS headliner material
- Custom woven aircraft carpet
- Fabricated dashboard and panels for tighter and cleaner fit
- Wonderbar radio incorporating Bluetooth technology
- Modified 1964 GM tilt column

DRIVELINE

22

- Buick 401 Nailhead
- Block and heads smoothed and polished
- Crank driven centrifical supercharger
- Custom-made billet mounting system for supercharger
- Custom-built front accessory drive
- Sequential fuel injection with single throttle body
- Billet inter-cooler
- Billet stud girdle and oil pan
- One-off billet main caps
- Custom billet crank shaft
- 4L80E 4 speed transmission with billet pan
- Custom oil pan incorporates dust cover and trans pan
- Block and heads meticulously ground and polished to eliminate gaps and parting lines

CHASSIS

30

- Hand-crafted rails and crossmembers
- Engineered IRS four link pocketed within the frame rails
- Machined front upper and lower control arms
- Baer brakes - six piston front and four piston rear
- One-off independent rear suspension
- Custom-built control arms, trailing arms and axles
- One-off broached splined hub carriers with stronger splines
- Suspension pieces painstakingly detailed through blasted satin nickel, polished nickel, satin paint, and pinstriping
- Penske coilovers
- Custom half shafts machined to resemble ball and socket joints

WHEELS

38

- 19x9 and 19x11 custom engineered wheels
- Multi-layer effect consists of 9 interlocking components
- Faux machined white wall
- 255/40R19 and 265/50R19 Pirelli tires

INVICTA 2-Door Hardtop (Model X60)

A racy, two-door hardtop with an exceptionally high rear window and generous glass area all around. A real performer-and it looks every bit the part.

BODY DIMENSIONS		Front	Rear
Over-all height	49.0"	Head room 32.75"	29.5"
Over-all width	80.0"	Shoulder room 60.6"	59.0"
Over-all length	222.0"	Hip room 65.9"	57.0"
Wheelbase	122.25"	Leg room 38.0"	25.25"
		Windshield	Total
		Glass area 1775.1 sq. in.	4875.3 sq. in.



BODY

Inspired by the Boeing B-52 Stratofortress the X60 Invicta Custom has refined lines and bodywork that is highlighted to give the illusion of driving fast and forward.

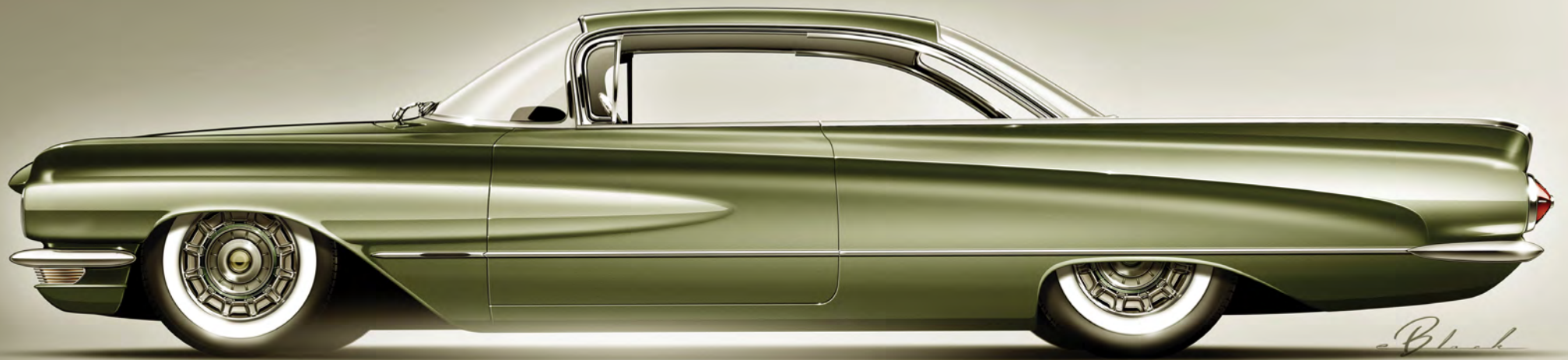

Black

BODY

Inspired by the Jet Age B-52, or Boeing B-52 Stratofortress, the X60 Invicta Custom features sleek lines perfected after countless hours of thoughtful reengineering. Wedged sections are present only in the front of the car, giving it the look of running downhill – full steam ahead. Its brass trim is CAD designed and precision machined, and its one-piece, precision-machined rear bumper delivers a refined and polished flow.

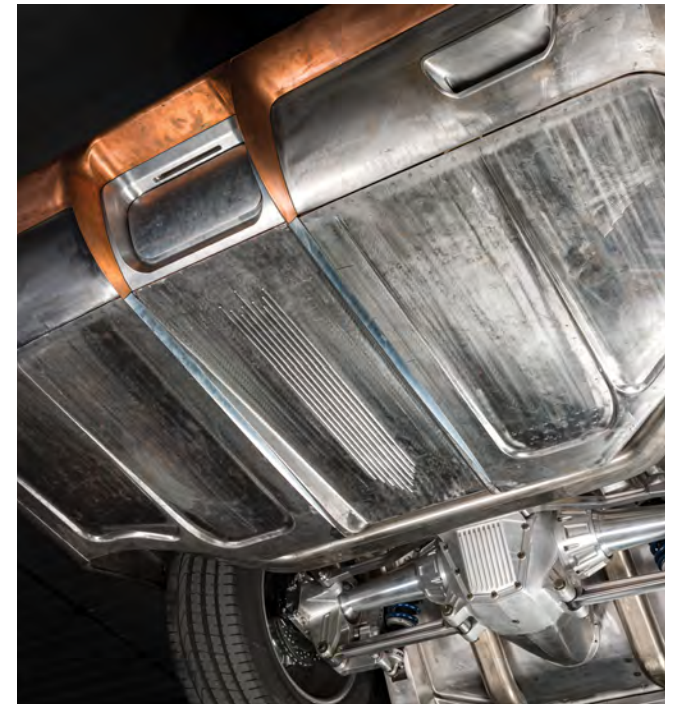









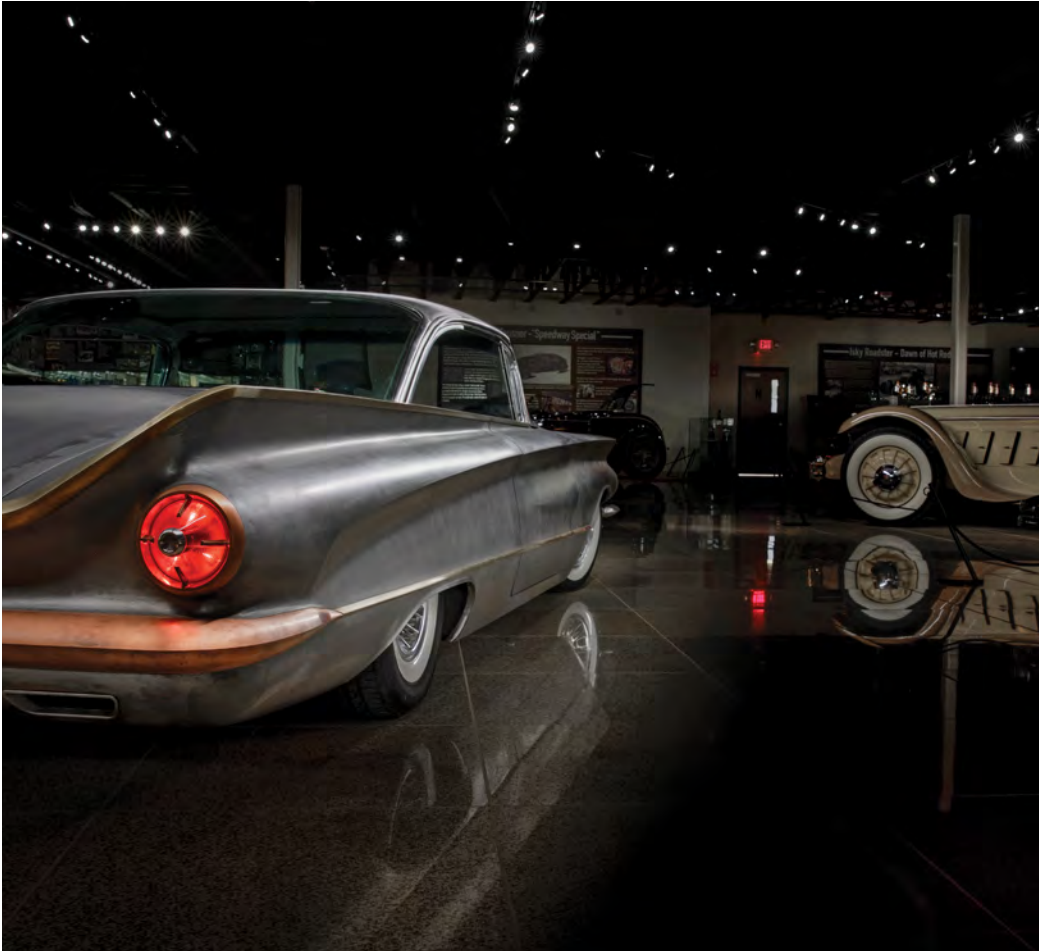



INTERIOR

Boasting with the coveted Invicta hardback bucket seats wasn't enough. Replicated in the rear with the most luxurious materials & refined center counsel, companions too get a taste of the elegance offered in the X60 Invicta Custom.

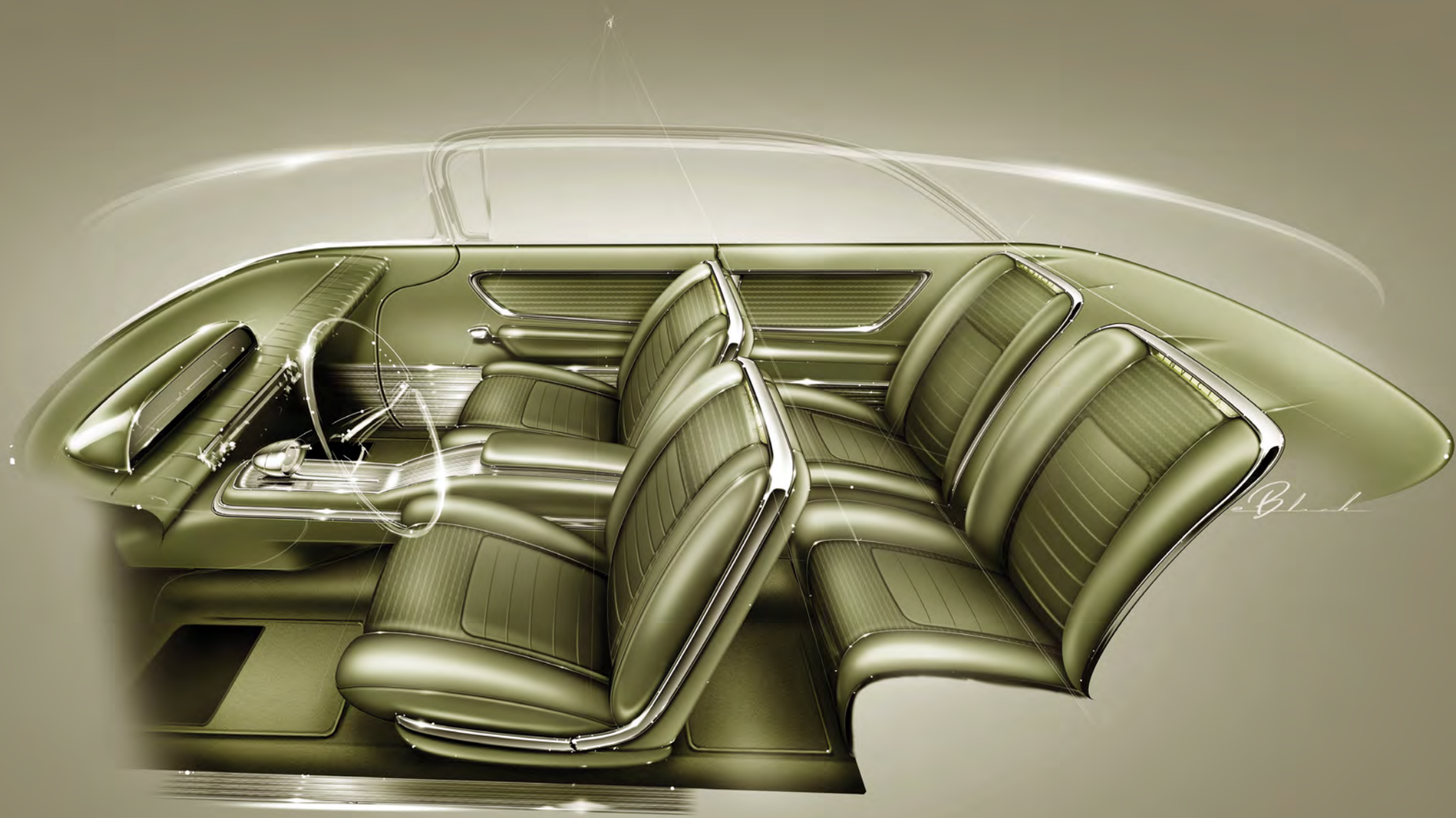

INTERIOR

In designing the interior of the X60 Invicta Custom, the goal was to keep the look and feel of the 1960 Buick, while elevating and polishing the visual experience. The interior is built around the iconic Invicta hardback bucket seats and center console, featuring custom logos and pockets. Custom-made pearlized leather and woven aircraft carpeting brings everything together for a seamless and aesthetically appealing ride.

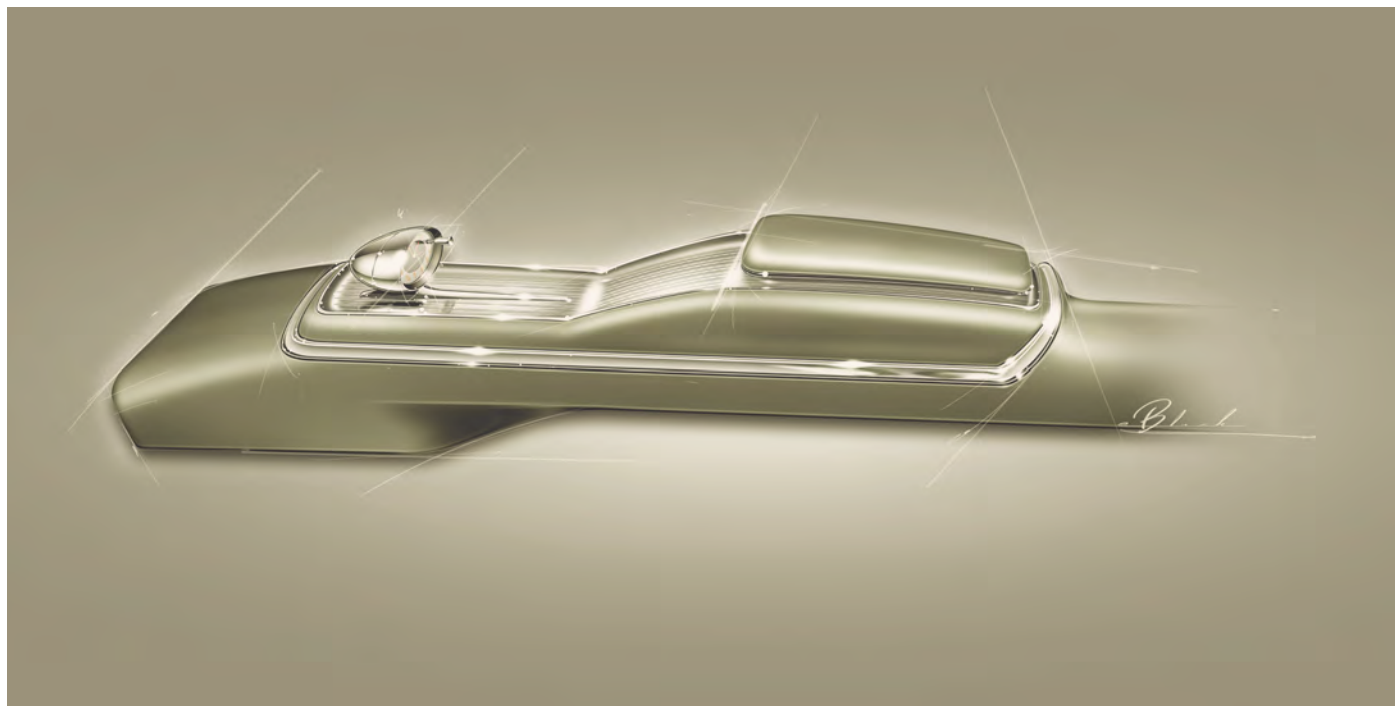
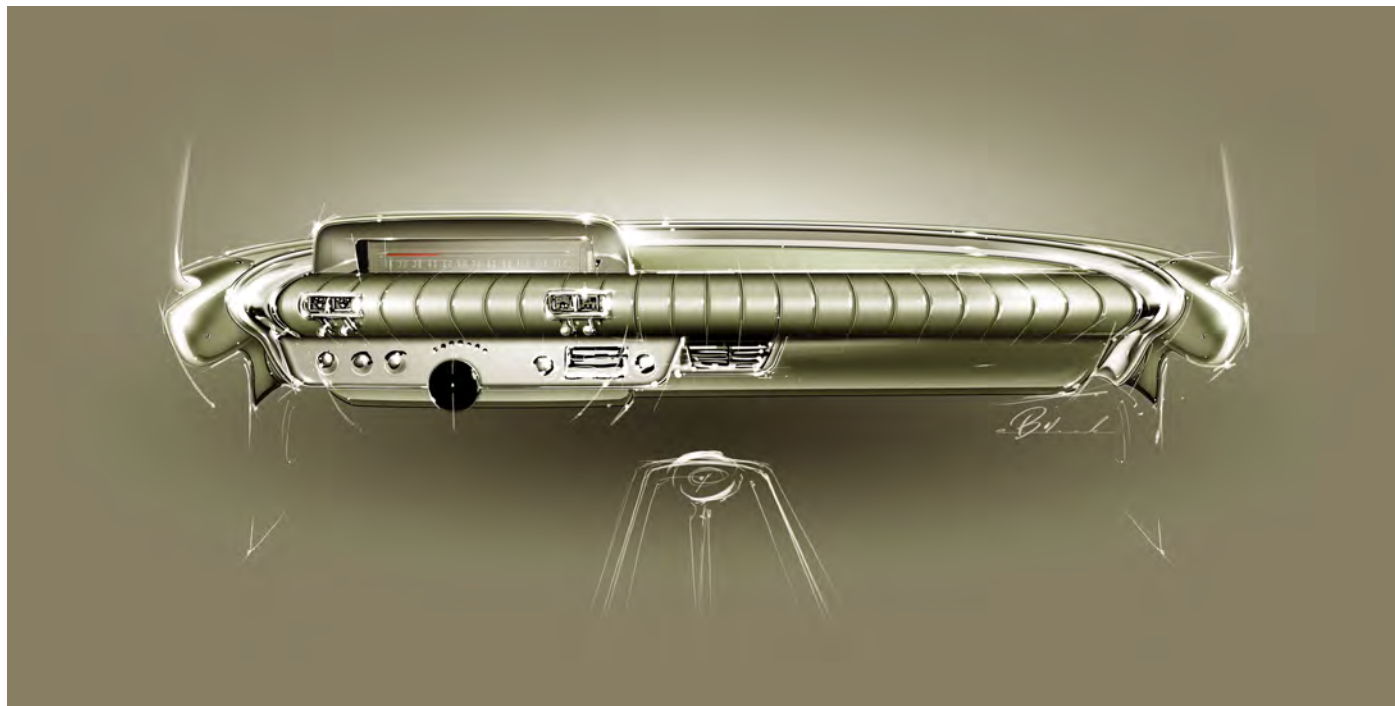

INVICTA *Custom* X60 Interior Details

Trim No.	<i>X60</i>
Interior Leather	<i>Cordaveen Green</i>
Interior Cloth	<i>Che-Se Diamond</i>

Trunk Mat	<i>Beaumont Verde</i>
Carpet	<i>Encryption</i>
Steering Wheel & Pedals	<i>Factory Invicta</i>











DRIVELINE

Just like its name, this X60 Invicta Custom is “unconquerable” with its performance and “undefeated” in it’s elegance.

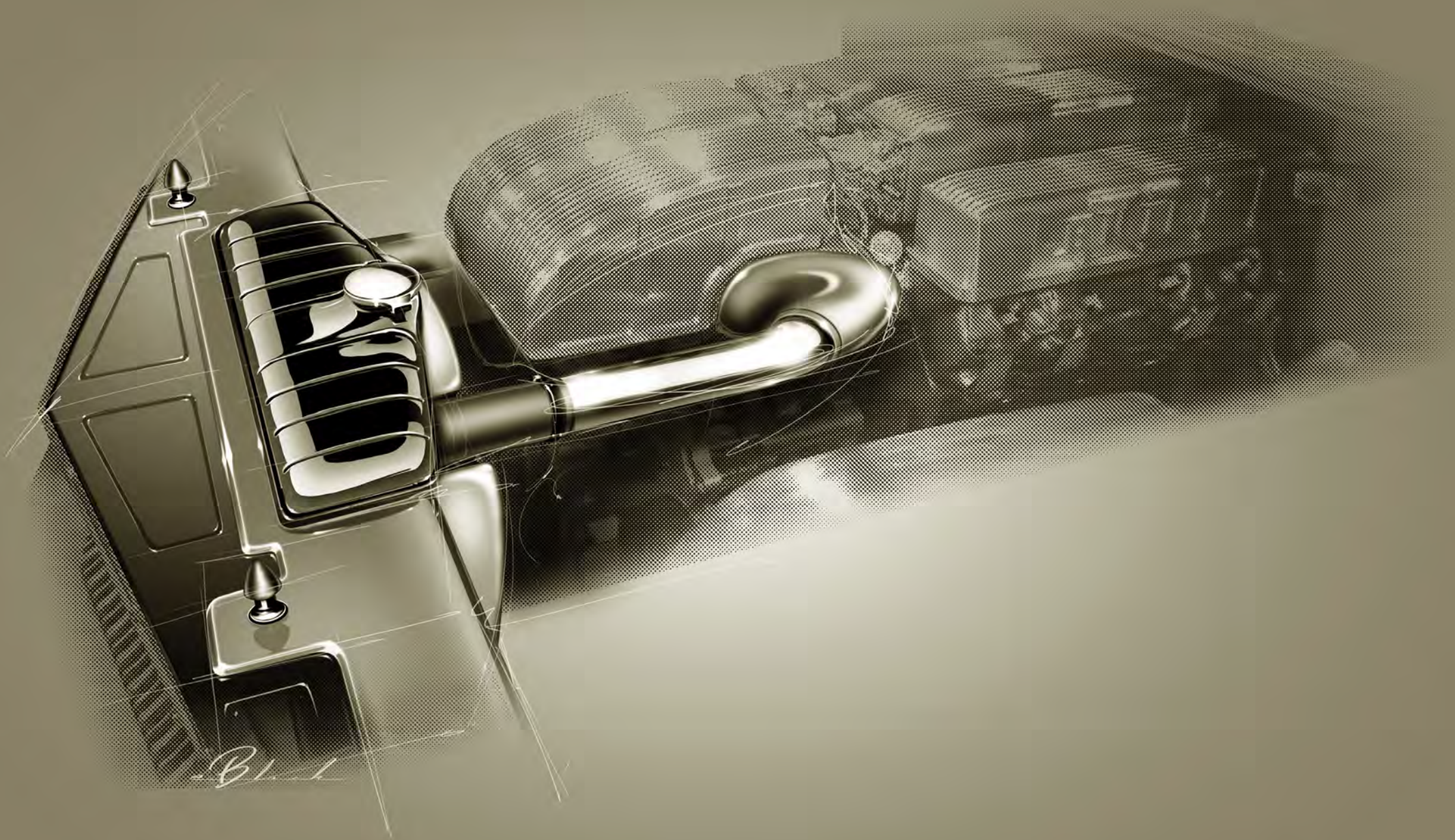

B.1

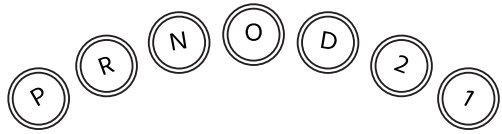

DRIVELINE

The X60 Invicta Custom stays true to its roots, outfitted with the same factory-correct 401 Nailhead engine block featured in the 1960 Buick. Featuring a crank-driven supercharger with custom-made bracketry for the blower, as well as power-steering, A/C and an alternator with a custom made front drive, it delivers a powerful driveline and an unmatched driving experience.

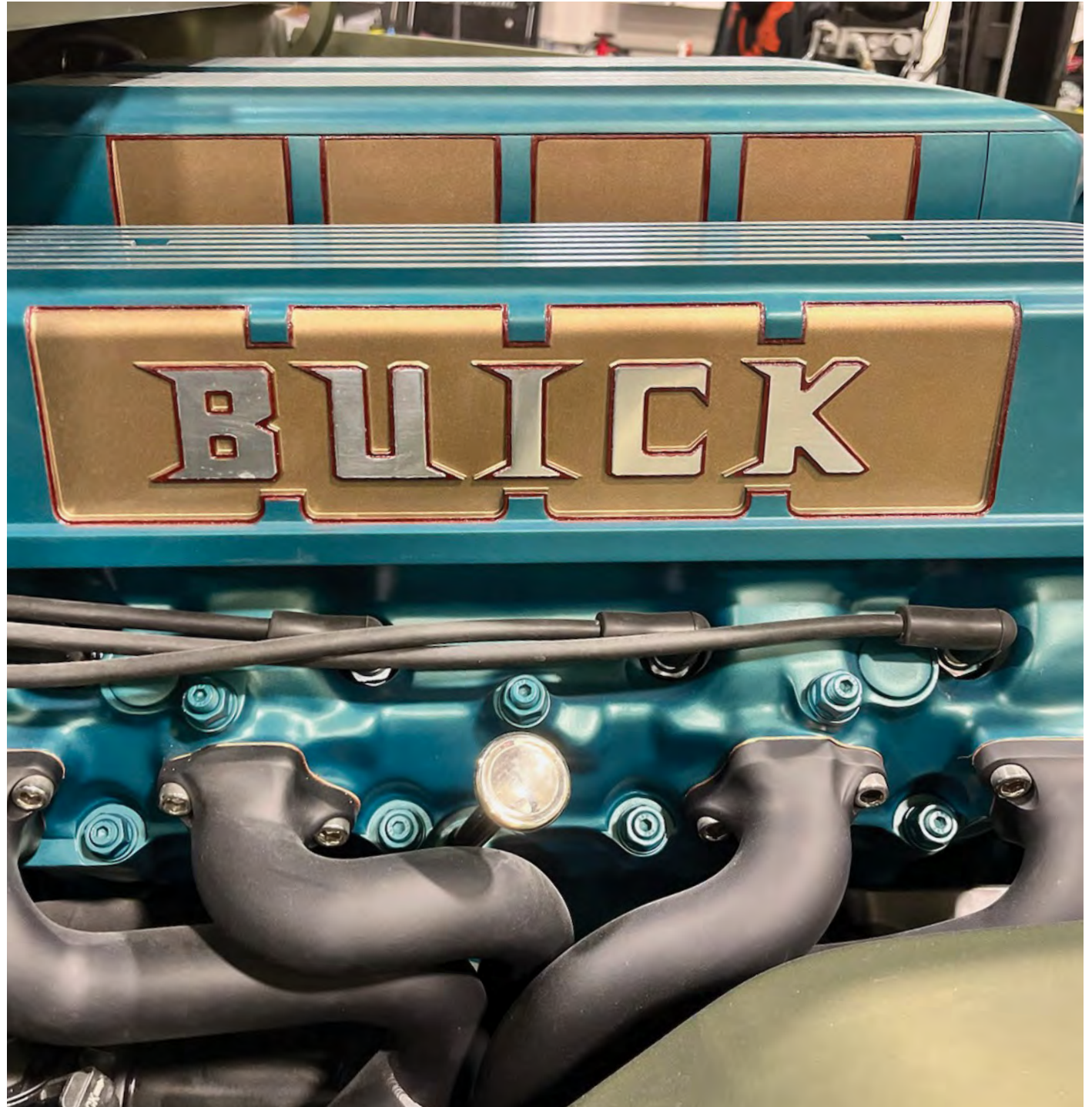

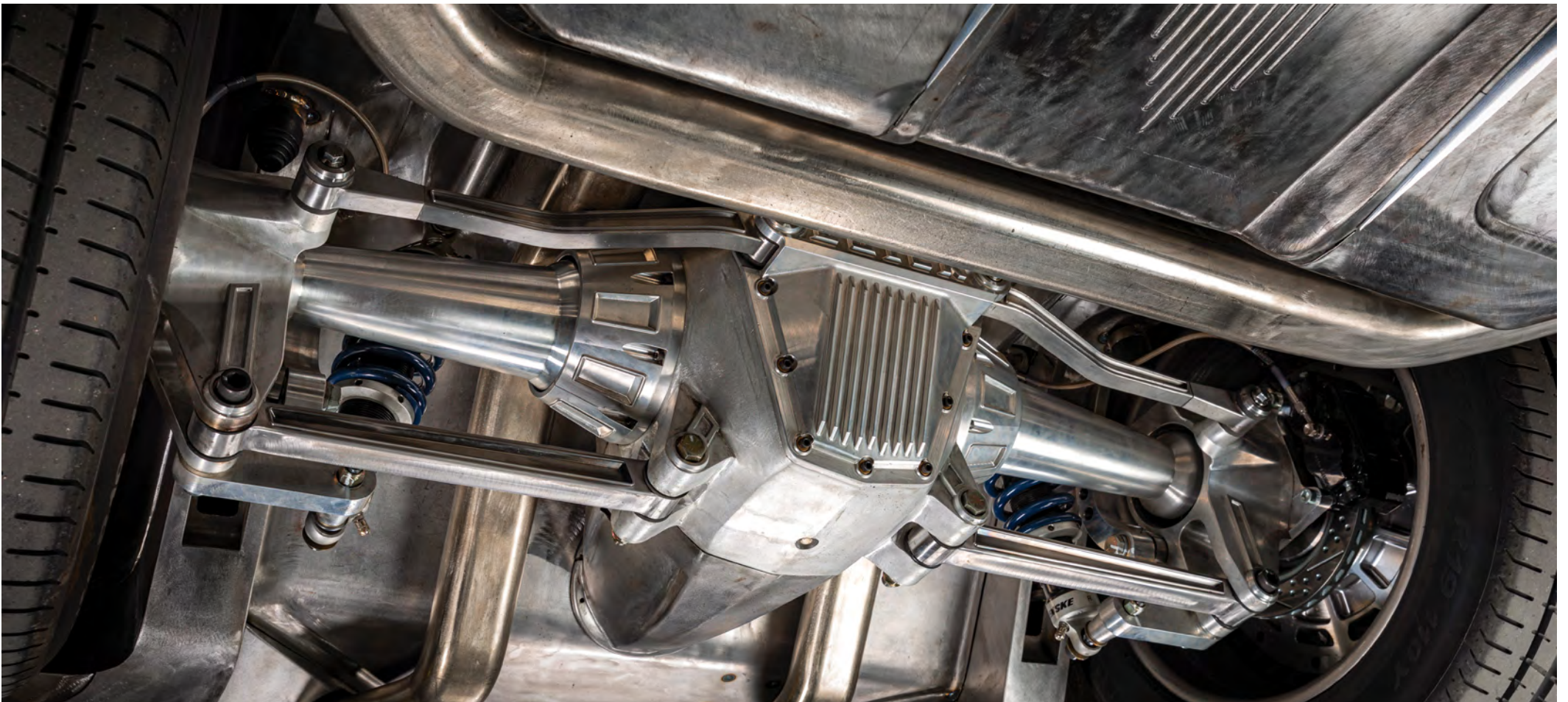
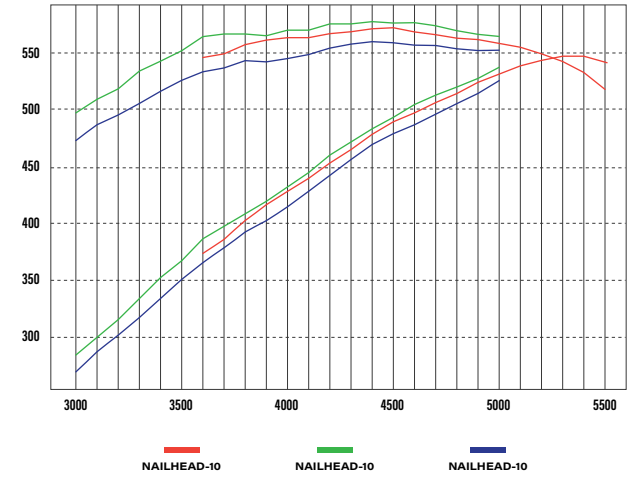



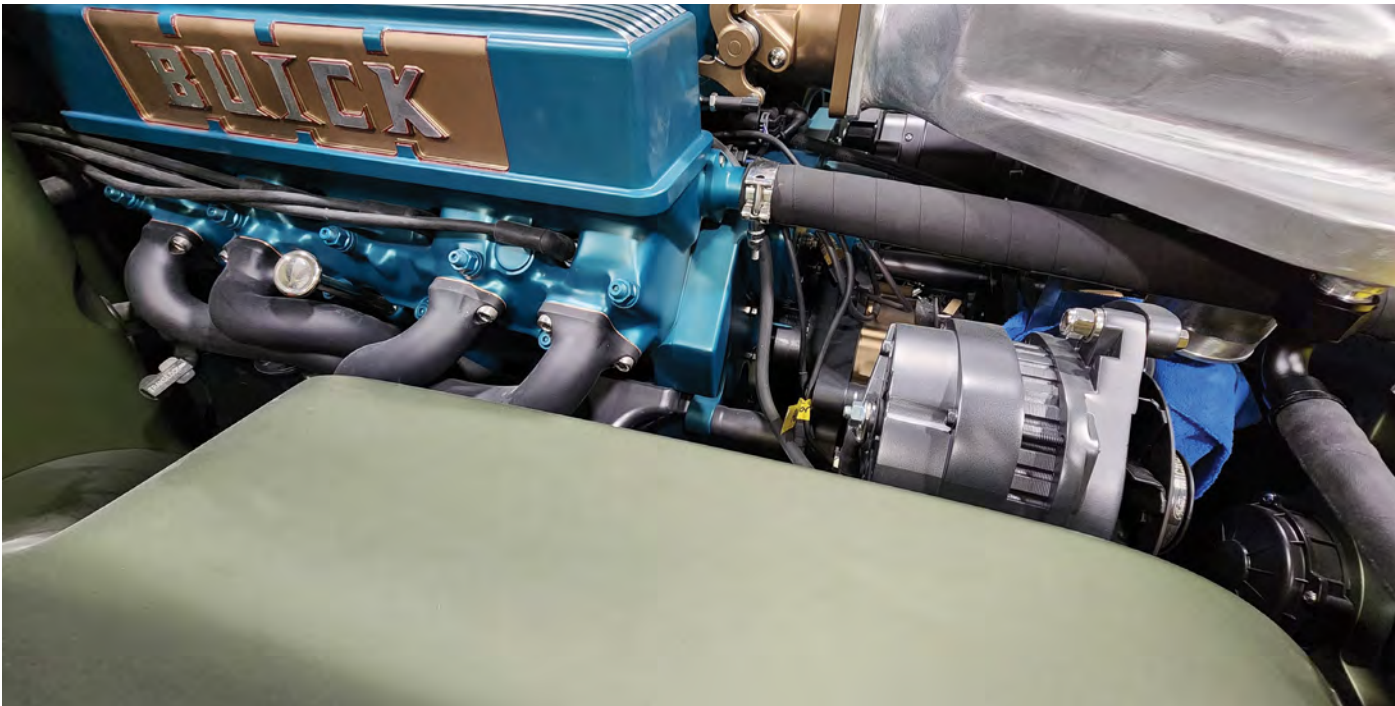



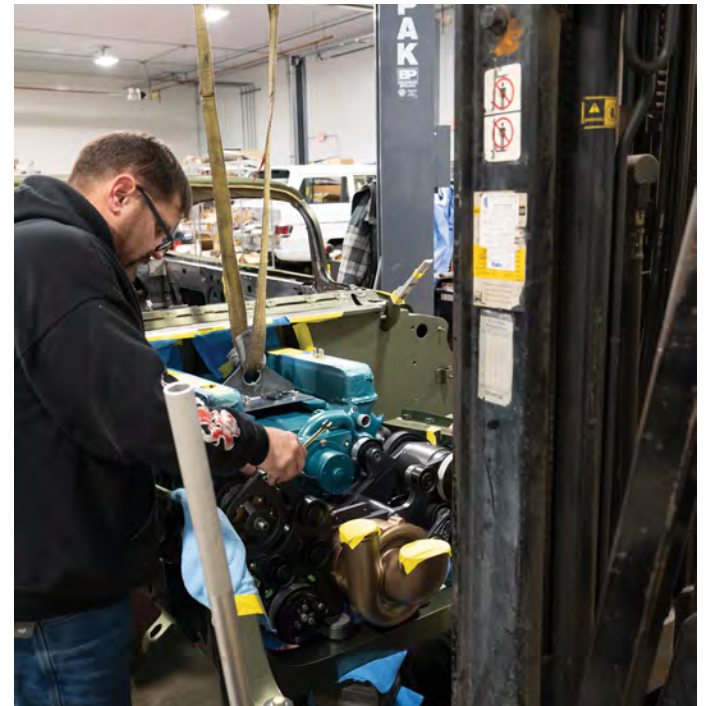
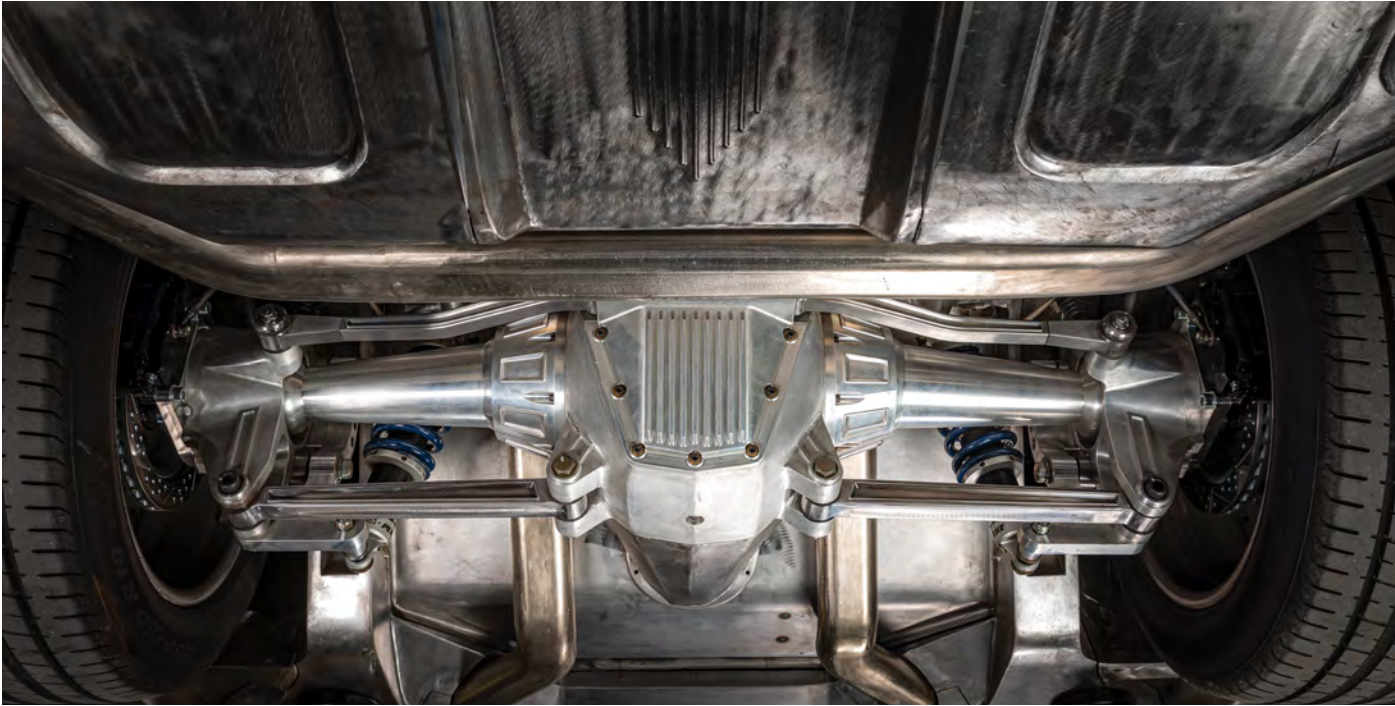



CHASSIS

*The bends and bumps in the road are of no concern of the X60 Invicta Custom; they're encouraged.
Its confidence drives from the reassurance it was built to outperform what may lie ahead.*

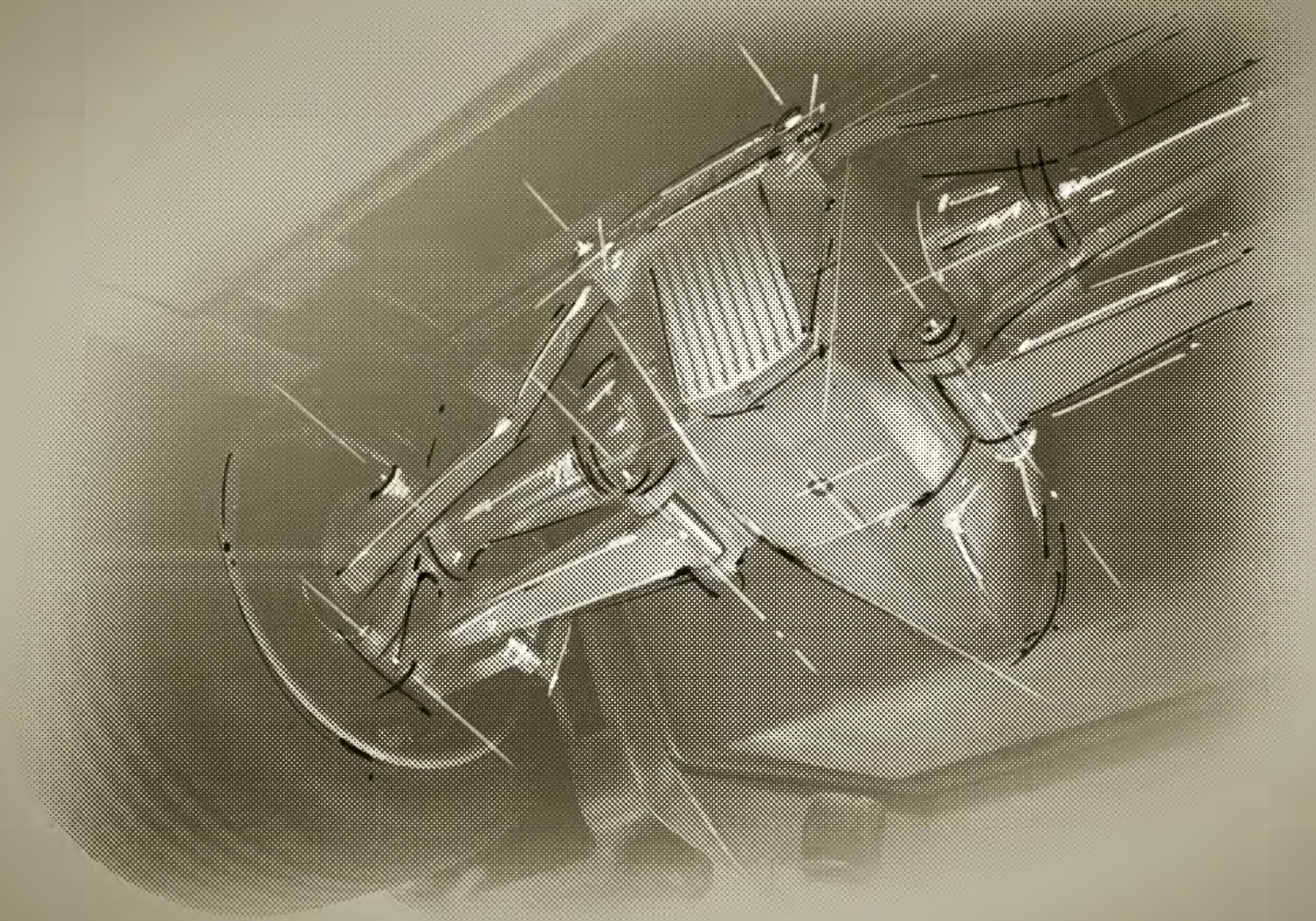

CHASSIS

The custom chassis features an abundance of exceptional details, including hand-crafted rails, crossmember, and machined front upper and lower control arms. The suspension pieces have been painstakingly detailed with blasted satin nickel, polished nickel, satin paint, and pinstriping. Every element has been built to spec to create the foundation for the X60 Invicta Custom.





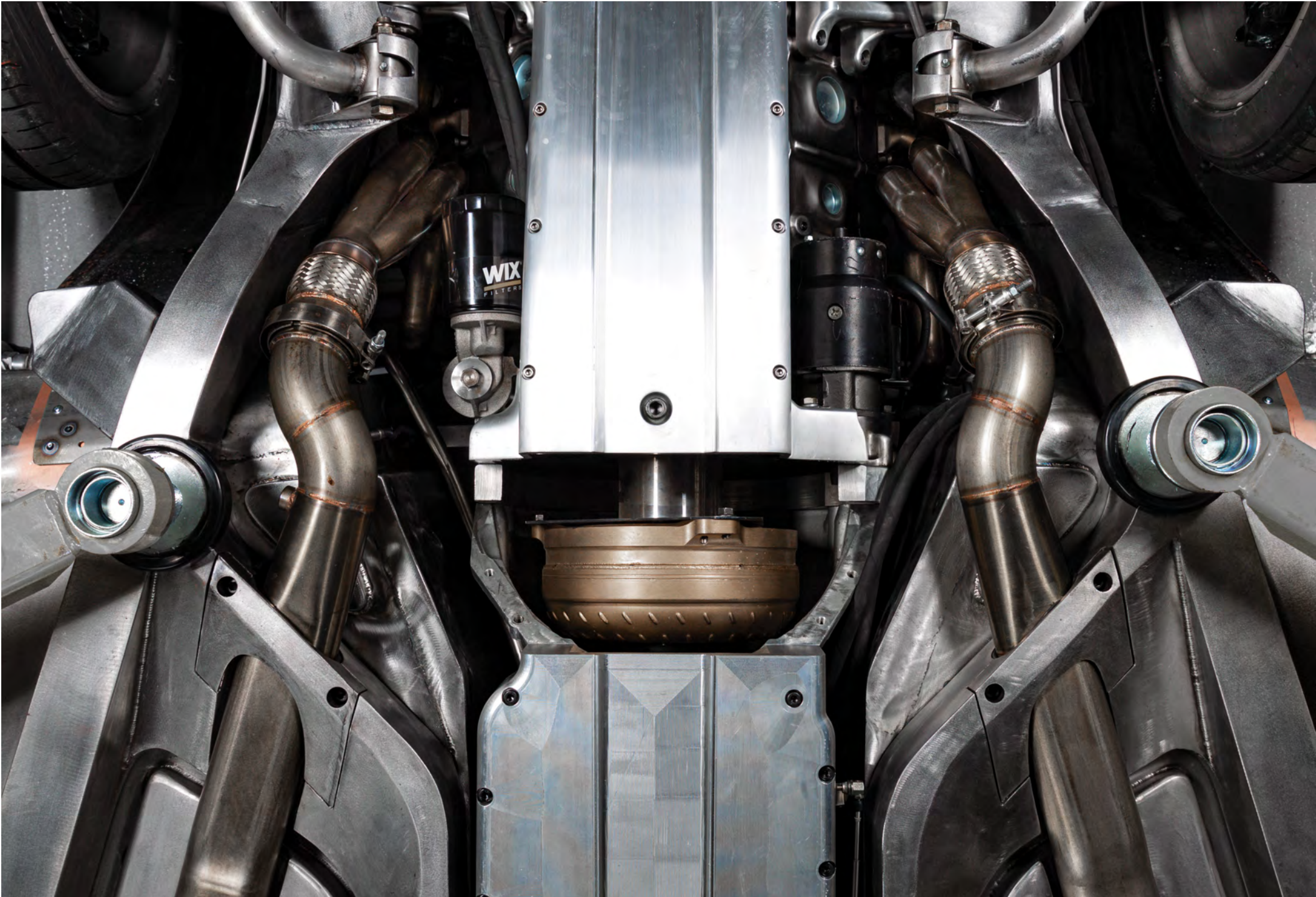





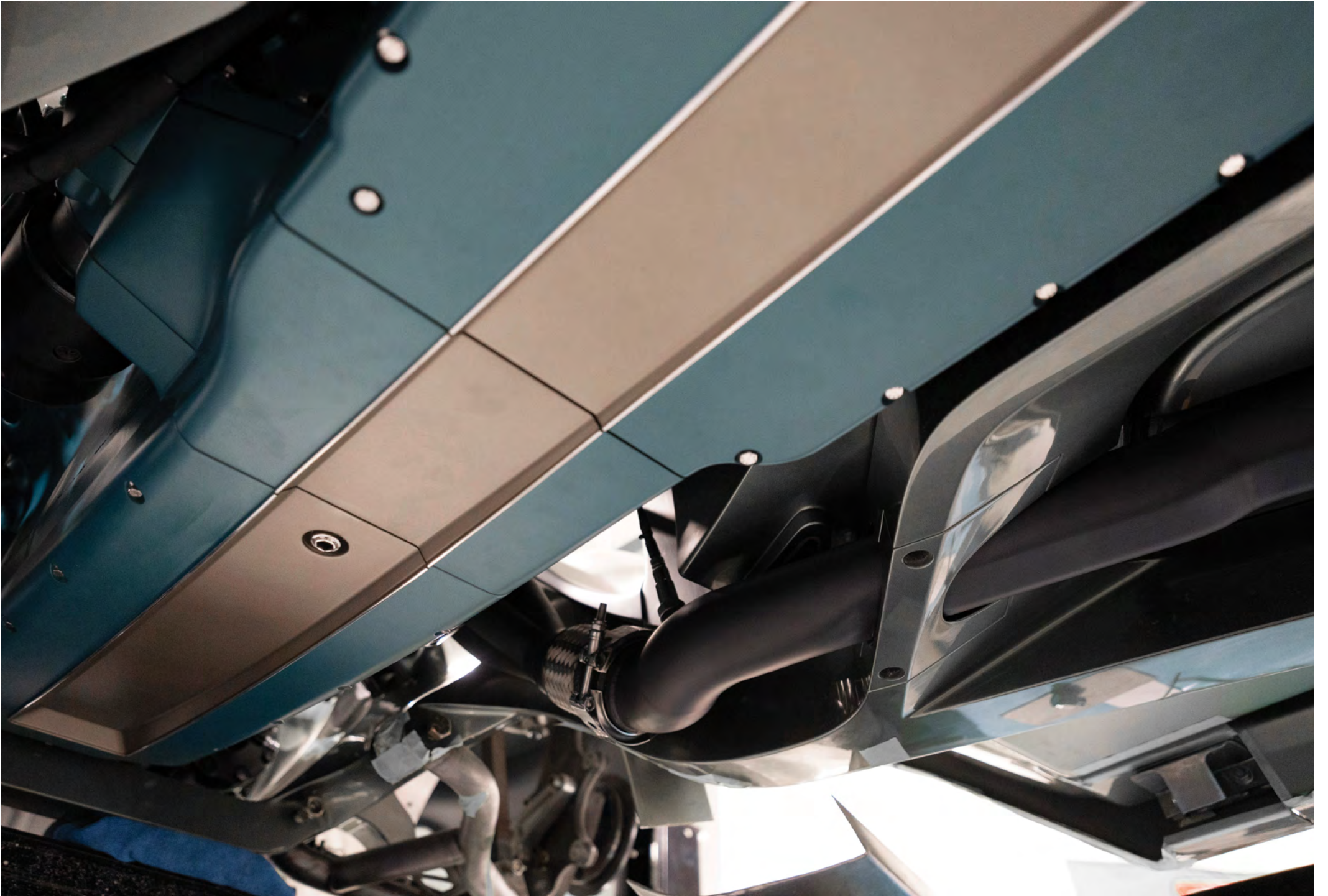



WHEELS

*The X60 Invicta Custom didn't reinvent the wheel,
it moved it forward.*

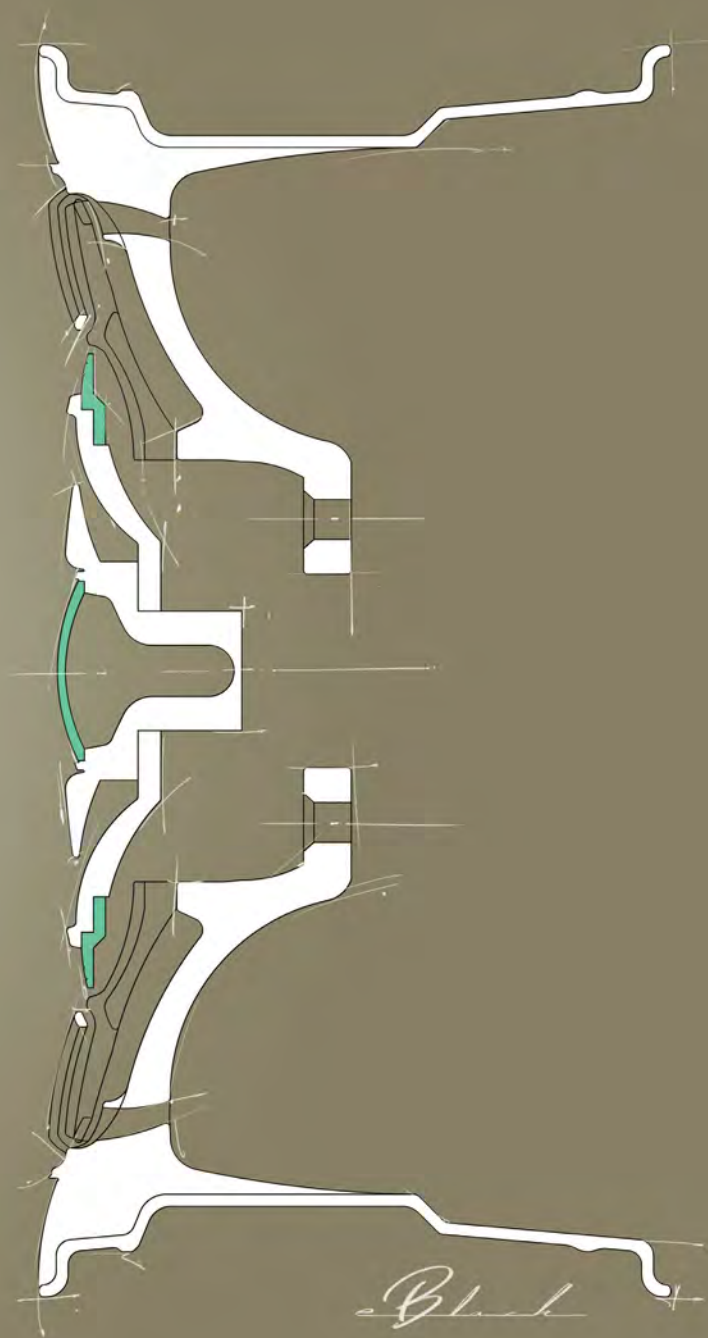

WHEELS

The X60 Invicta Custom showcases an elegant and timeless aesthetic on every level. You'll see this reflected in its multi-layer, one-of-a-kind wheel, which has been precisely designed to resemble a 15" factory style wheel with a futuristic touch. Notice the 9 interlocking components paired with a faux machined white wall, there's nothing like it.

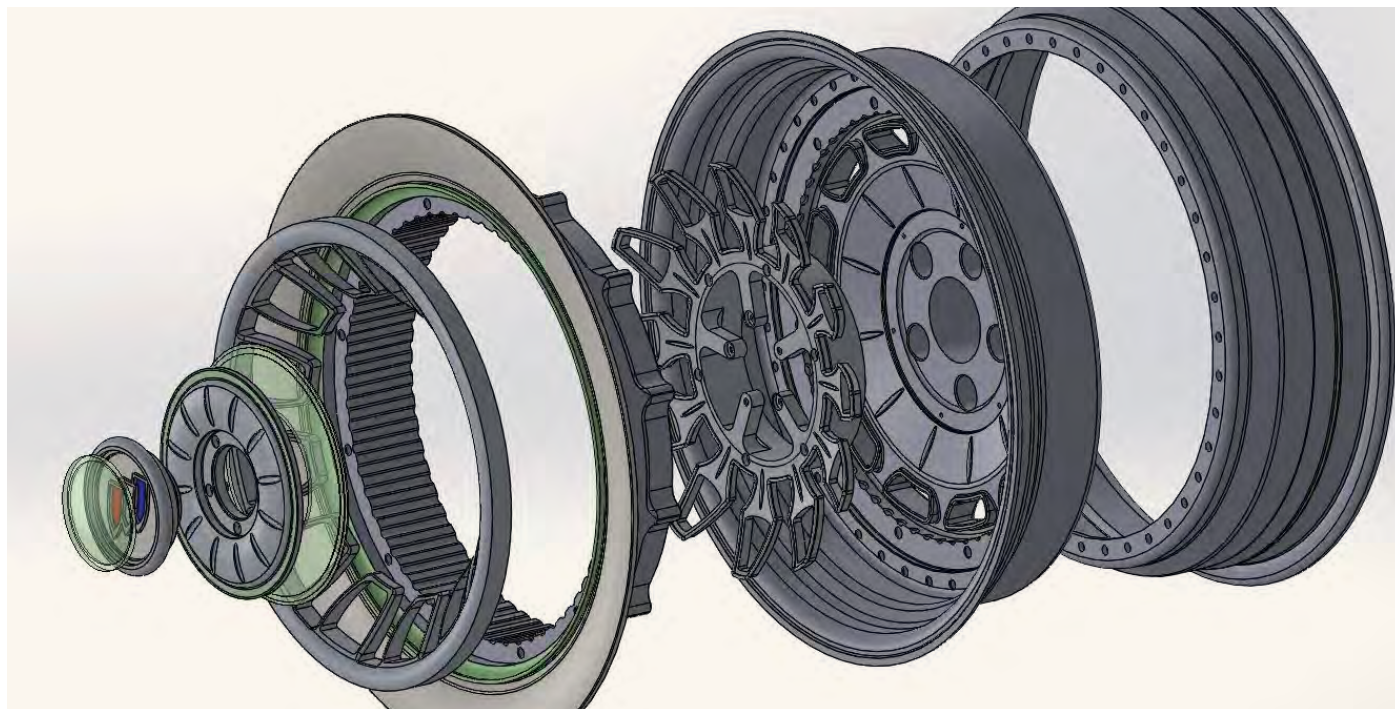

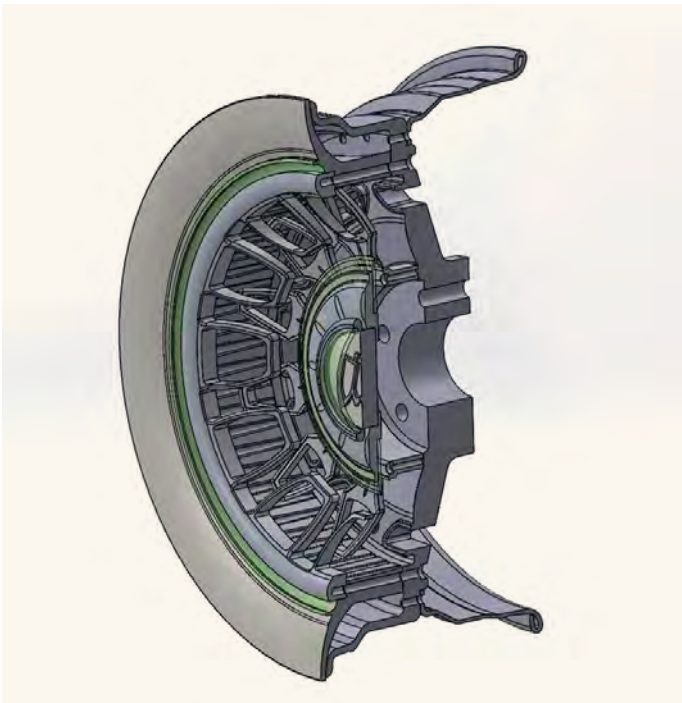



INVICTA *Custom*

INVICTA *Custom*

X60 Invicta Custom | *by Cal Automotive Creations*

CAL AUTO CREW

- Andy Leach: Owner
- Dalton Keeler: Fabrication
- Earl Boldra: Machining
- Erik Hanson: Design & Fabrication
- Ethan Jansen: Bodywork
- Jim Karls: Engineering CAD Designer
- Matt Summers: Paint & Mechanical
- Paul Caruana: Lead Fabricator
- Sam Gengenbach: Assembly & Fabrication
- Scott Schneckloth: Bodywork
- Steve Socha: Fabrication

PARTNERS & AFFILIATES

- Advanced Plating
- All Girls Transportation
- ARP
- Atomic Machine and Design
- Baer Brakes
- Bowler Performance Transmission
- Coach Controls
- Consuming Air Design
- Dakota Digital
- DDS Enterprises
- DEI
- Disomma Racing Engines
- Don Bailey Enterprises
- e.Black / eBDCo
- Evod Industries
- Keystone Automotive Operations
- Larry Williams Graphics
- Leading Edge Machine & Design
- Mobile Mike Wiring
- Painthouse
- Relicate Leather
- Renze Display
- Sherwin-Williams
- Soundz Plus
- Speedway Motors
- Starline Hot Rod Interiors
- Studio Mass
- Vintage Air
- Wheel Hub Magazine
- WMC Inc.

SPECIAL THANKS

- Annali Leach
- Bill Legenza
- Bryan Lemonds
- Elliott Wilson
- Greg Zessin
- Kyle Ray
- Mike Swain
- Rich Carli
- Rick Ulfers
- Skyler Babko



calautocreations.com | *Bennington, Nebraska*